

SIZE		Main dimensions(mm)		
DN	INCH	L	D	D1
50	2	19	109	25
65	2.5	19	129	38
80	3	19	144	46
250	10	29	332	188

Tolerance for linear dimensions:
 1)Length: 10-250mm, tolerance: ± 2.0 mm.
 2)Length: 250-500mm, tolerance: ± 3.0 mm.
 3)Length: 500-800mm, tolerance: ± 4.0 mm.
 4)Length: 800-1000mm, tolerance: ± 5.0 mm.
 5)Length: 1000-1600mm, tolerance: ± 6.0 mm.
 6)Length: 1600-2250mm, tolerance: ± 8.0 mm.

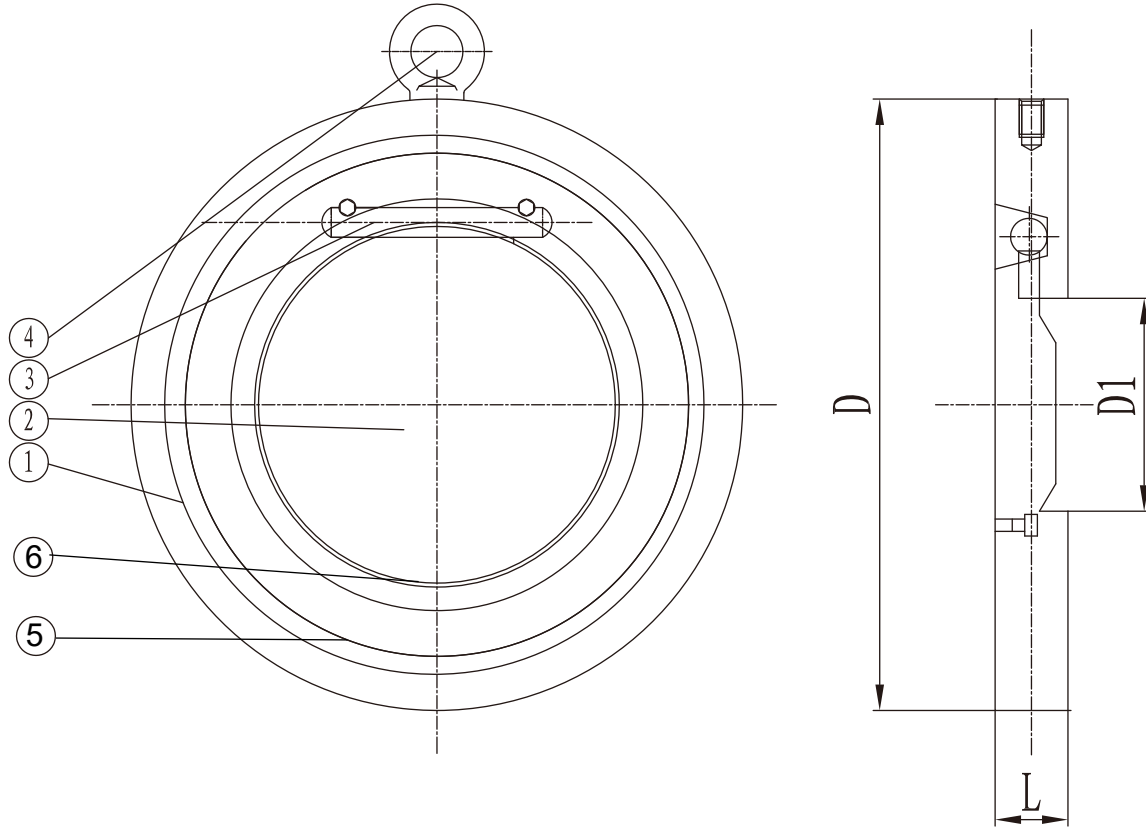

Technical Specification		
Nominal Pressure		1.6
Test Pressure	Shell	2.4
	Seal	1.76
	Air Seal	0.6
Working Temperature		≤ 200
Working Medium:		Water

TECHNICAL REQUIREMENTS

- 1.DESIGN AND MANUFACTURER STANDARD: JB/T8937;
- 2.FACE TO FACE STANDARD: JB/T8937;
- 3.INSPECTION AND TEST STANDARD: EN 12266-1;

6	Seat	VITON	
5	Seal	VITON	
4	Hanging ring	316	
3	Stem	316	
2	Disc	316	
1	Body	316	
NO.	Item	Material	Remark