

KULLANIM KILAVUZU / *USER MANUEL*

PA1037 / PA1055 / PA1075 PLASTİK ASİT POMPASI

PA1037 / PA1055 / PA1075 PLASTIC ACID PUMPS



MEKANİK SALMASTRALI PLASTİK ASİT POMPALARI
MECHANICAL SEAL PLASTIC ACID PUMPS

KAYNAK BAĞLANTI

FEMALE SOLVENT SOCKET

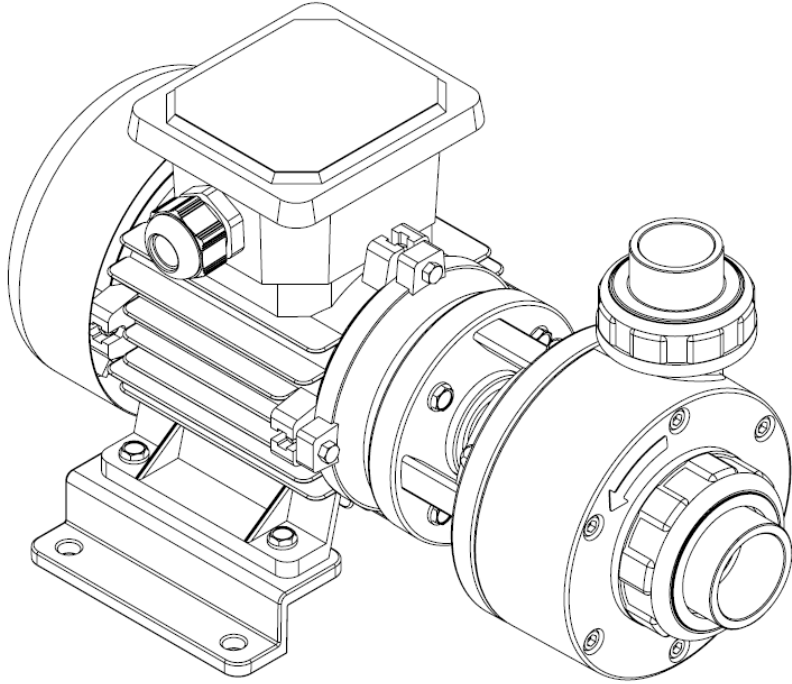

HORTUM REKORLU BAĞLANTI

HOSE FITTING

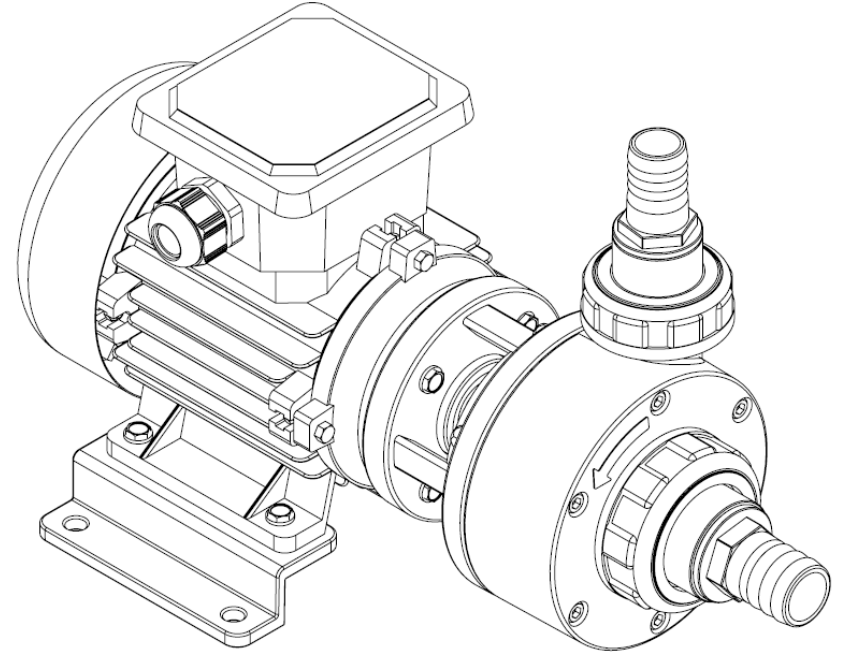

PERFORMANS EĞRİSİ / PERFORMANCE CURVES

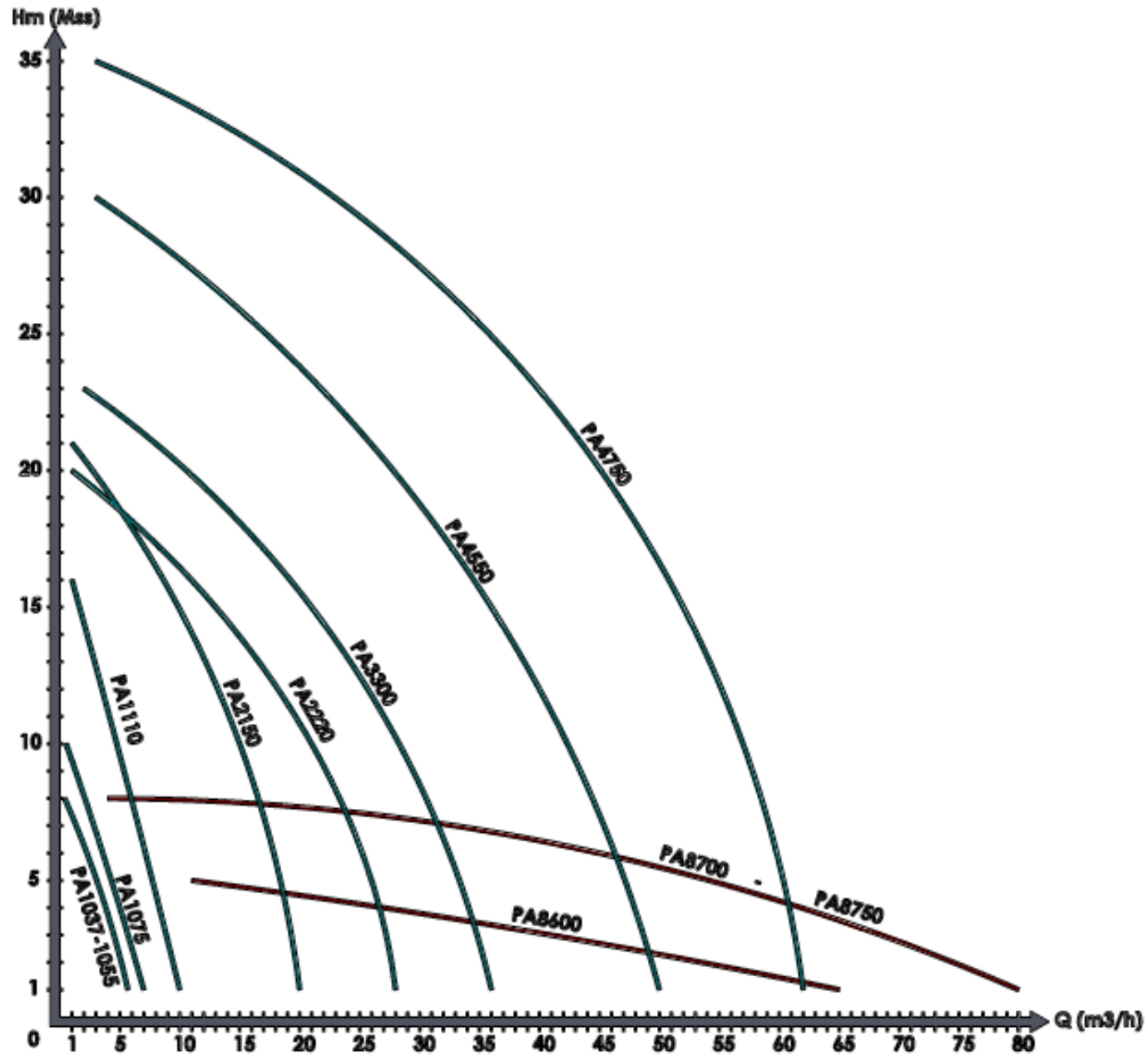

ÖLÇÜLENDİRME [mm] / DIMENSIONS [mm]

Ölçü toleransı ± 3 mm / Dimensional tolerances ± 3 mm

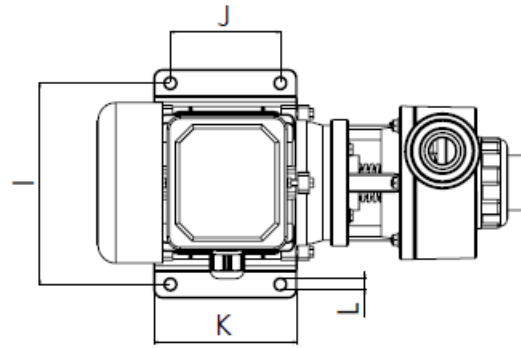
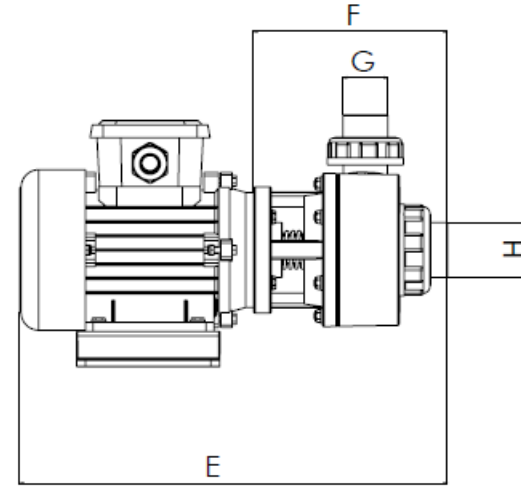
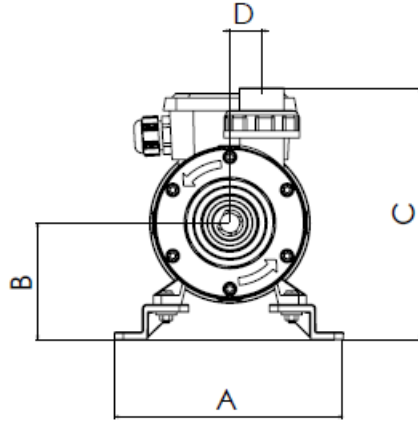

A	B	C	D	E	F	G	H	I	J	K	L
207.5	106.5	229	29	389	177	DN32	DN40	183	100	129	10

PAKETLEME [mm] / PACKAGING [mm]

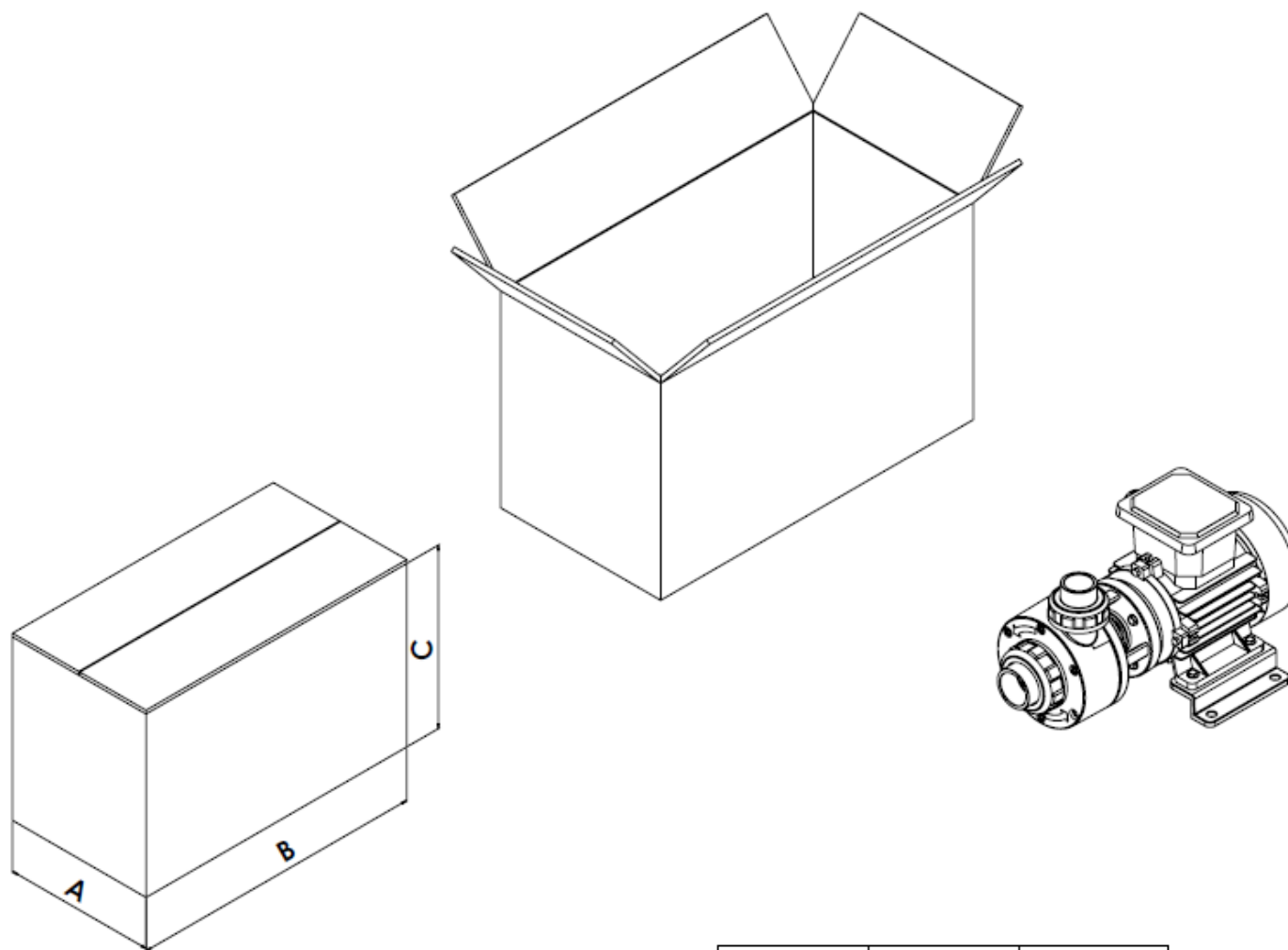

A	B	C
270	500	340

PLASTİK ASİT POMPA YEDEK PARÇA RESMİ / PLASTIC ACID PUMP SPARE PARTS DRAWING

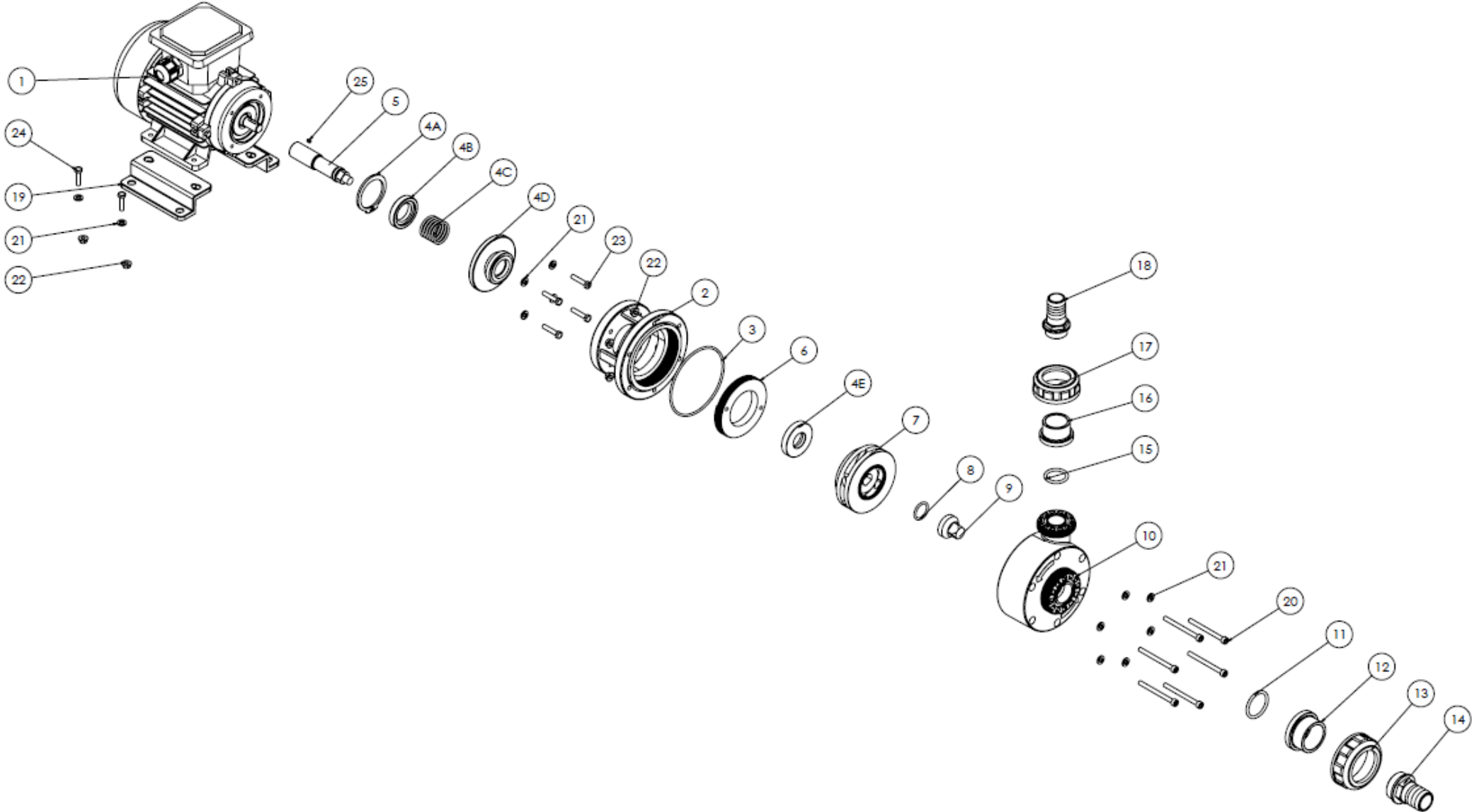

PLASTİK ASİT POMPA PARÇA LİSTESİ / PLASTIC ACID PUMP SPARE PARTS LIST

1	1037-110	Elektrik Motoru / <i>Electric Motor</i>	1	7	1037-170	Fan / <i>Impeller</i>	1
	1055-110	Elektrik Motoru / <i>Electric Motor</i>	1		1055-170	Fan / <i>Impeller</i>	1
	1075-110	Elektrik Motoru / <i>Electric Motor</i>	1		1075-170	Fan / <i>Impeller</i>	1
2	1037-120	Gövde / <i>Body</i>	1	8	1100-180	Oring / <i>Oring</i>	1
	1055-120	Gövde / <i>Body</i>	1	9	1100-190	Fan Sıkma Somunu / <i>Impeller Tightening Nut</i>	1
	1075-120	Gövde / <i>Body</i>	1	10	1100-200	Kapak / <i>Pump Cover</i>	1
3	1100-130	Oring / <i>Oring</i>	1	11	1100-210	Oring / <i>Oring</i>	1
4	1100-140	Mekanik Salmastra / <i>Mechanical Seal</i>	1	12	1100-220	Boru Bağlantı / <i>Female Solvent Socket</i>	1
4A	1100-142	Segman / <i>Segment</i>	1	13	1100-230	Somun / <i>Plastic Nut</i>	1
4B	1100-143	Yay Dayaması / <i>Spring Stop</i>	1	14	1100-235	Hortum Rekoru 1 ¼" / <i>Hose Fitting 1 ¼"</i>	1
4C	1100-144	Yay / <i>Spring</i>	1	15	1100-240	Oring / <i>Oring</i>	1
4D	1100-145	Mekanik Salmastra (Sabit) / <i>M. Seal (Fixed)</i>	1	16	1100-250	Boru Bağlantı / <i>Female Solvent Socket</i>	1
4d1	1100-210	Silisyum / <i>Silisyum</i>	1	17	1100-260	Somun / <i>Plastic Nut</i>	1
4d2	1100-220	Seramik / <i>Ceramic</i>	1	18	1100-265	Hortum Rekoru 1" / <i>Hose Fitting 1"</i>	1
4d3	1100-230	R.Karbon / <i>Resin Carbon</i>	1	19	1100-270	Motor Bağlantı Ayağı / <i>Electric Motor Bracket</i>	2
4E	1100-146	Mekanik Salmastra (Hareketli) / <i>M. Seal (Moving)</i>	1	20	CM6X70-IP	Cıvata M6 X 70 / <i>Capscrew M6 X 70</i>	5
4e1	1100-310	R.Karbon / <i>Resin Carbon</i>	1	21	PM6-P	Pul M6 / <i>Washer M6</i>	13
4e2	1100-320	A.Karbon / <i>A. Carbon</i>	1	22	SM6-FP	Somun Flaşlı M6 / <i>Nut Flanged M6</i>	9
4e3	1100-330	Silisyum / <i>Silisyum</i>	1	23	CM6X25-P	Cıvata M6 X 25 / <i>Capscrew M6 X 25</i>	4
5	1100-150	Mil / <i>Shaft</i>	1	24	CM6X30-P	Cıvata M6 X 30 / <i>Capscrew M6 X 30</i>	4
6	1100-160	Salmastra Somunu / <i>M. Seal Tightening Nut</i>	1	25	ST5X8-P	Setskur M5x8 / <i>Screw Bolt M5x8</i>	1



BAKIM, ONARIM VE KULLANIMDA UYULMASI GEREKENLER / MAINTENANCE, REPAIR AND USE REQUIREMENTS

PLASTİK ASİT POMPALARI ELEKTRİKLİ VE MEKANİK SALMASTRALI OLUP DAHA ÇOK KİMYASAL AKIŞKAN TRANSFERLERİNDE KULLANILIRLAR. POMPALAR KENDİNDEN EMİŞLİ DEĞİLDİR. KURU ÇALIŞMAZLAR.

PLASTIC ACID PUMPS HAVE ELECTRICAL AND MECHANICAL SEALS AND ARE MORE USED IN CHEMICAL FLUID TRANSFER. PUMPS ARE NOT SELF-PRICING. DO NOT WORK DRY.

POMPANIN BAĞLANTISI YAPILIRKEN AKIŞKANIN POMPAYA KENDİ AKARIYLA GELMESİNE DİKKAT EDİLMELİDİR. EĞER BU İMKAN YOKSA POMPANIN EMİŞ HATTININ UCUNA ÇEKVALF KONULARAK EMİŞ HATTI TAMAMEN AKIŞKAN İLE DOLDURULDUKTAN SONRA POMPANIN ÇALIŞMASI SAĞLANMALIDIR.

WHEN CONNECTING THE PUMP, MUST BE CAREFUL THAT THE FLUID COMING TO THE PUMP WITH ITS OWN FLOW. IF THIS OPPORTUNITY IS NOT AVAILABLE, THE PUMP MUST WORK AFTER THE SUCTION LINE IS FULLY FILLED WITH FLUID, BY PLACING A CHECK VALVE ON THE END OF THE SUCTION LINE OF THE PUMP.

PLASTİK ASİT POMPALARI SANTRİFÜJ TİP POMPA OLDUKLARI İÇİN YÜKSEK MOTOR DEVİRLERİNDE ÇALIŞIRLAR. (1500 RPM – 3000 RPM) BAĞLANTI ESNASINDA EMİŞ VE BASMA HATLARINDA KESİTİ DÜŞÜRECEK REDÜKSİYON KULLANILMAMALIDIR. KULLANILDIĞI DURUMLARDA İSTENİLEN DEBİ VE BASINÇ DEĞERLERİ SAĞLANMAZ.

PLASTIC ACID PUMPS WORK AT HIGH ENGINE RPM BECAUSE THEY ARE CENTRIFUGAL TYPE. (1500 RPM – 3000 RPM) DURING THE CONNECTION, REDUCTIONS TO REDUCE THE SUCTION AND SUCTION LINES SHOULD NOT BE USED. DESIRED FLOW AND PRESSURE VALUES ARE NOT PROVIDED WHEN USED.

PLASTİK ASİT POMPALARI MEKANİK SALMASTRALI OLDUKLARI İÇİN AKIŞKAN İÇERİSİNDE ÇOK FAZLA PARTİKÜL BULUNMASI POMPAYA ZARAR VERİR. BU DURUMDA POMPANIN EMİŞ HATTININ ÖNÜNE FİLTRE TAKILMALIDIR.

BECAUSE PLASTIC ACID PUMPS ARE MECHANICAL SEALS, THE PRESENTATION OF LOTS OF PARTICLES IN THE FLUID WILL DAMAGE THE PUMP. IN THIS CASE, A FILTER MUST BE INSTALLED IN FRONT OF THE SUCTION LINE OF THE PUMP.



TAŞIMA VE NAKLİYE SIRASINDA DİKKAT EDİLMESİ GEREKENLER / THINGS TO BE CONSIDERED DURING HANDLING AND SHIPMENT

PLASTİK ASİT POMPALARI TAŞINABİLİR KOLİ AMBALAJ İLE SEVK EDİLİR. PLASTİK MALZEMEDEN ÜRETİLDİKLERİ İÇİN NAKLİYE SIRASINDA ZARAR GÖRMEMESİ İÇİN KOLİ ÜZERİNE KIRILABİLİR UYARI İŞARETLERİ KULLANILMALIDIR.

PLASTIC ACID PUMPS ARE SHIPPED WITH PORTABLE BOX PACKAGING. BECAUSE THEY ARE MADE OF PLASTIC, FRAGILE WARNING SIGNS MUST BE USED ON THE PACKAGING TO AVOID DAMAGE DURING SHIPPING.



KULLANIM VE ÇALIŞMA SIRASINDA DİKKAT EDİLMESİ GEREKENLER / THINGS TO BE CONSIDERED DURING USE AND OPERATION

POMPA ÇALIŞTIRILMADAN ÖNCE KİMYASALA DAYANIKLI ELDİVEN VE GÖZLÜK KULLANILMALIDIR.

CHEMICAL RESISTANT GLOVES AND GOGGLES MUST BE USED BEFORE STARTING THE PUMP.

POMPANIN BAĞLANTI CİVATALARI KONTROL EDİLMELİDİR.

THE CONNECTION BOLTS OF THE PUMP MUST BE CHECKED.

POMPANIN EMİŞ VE BASMA BAĞLANTILARI KONTROL EDİLMELİDİR..

SUCTION AND SUCTION CONNECTIONS OF THE PUMP MUST BE CHECKED.

POMPANIN ELEKTRİK MOTORU BAĞLANTISI KONTROL EDİLMELİDİR.

THE ELECTRIC MOTOR CONNECTION OF THE PUMP MUST BE CHECKED.

POMPANIN EMİŞ VE ÇIKIŞ HATTINDAKİ VANALAR KONTROL EDİLMELİDİR.

VALVES IN THE SUCTION AND OUTPUT LINE OF THE PUMP MUST BE CHECKED.



KULLANIM HATALARI / USE ERRORS

PLASTİK ASİT POMPALARI ÇALIŞMA PRENSİBİ OLARAK OLDUKÇA BASİT POMPALARDIR. POMPALARDA YAŞANAN EN BÜYÜK SORUNLARIN BAŞINDA KURU ÇALIŞMA GELMEKTEDİR. POMPA AKIŞKANI TRANSFER EDERKEN KURU KALDIĞI ZAMAN, SALMASTRA AŞIRI ISINARAK YANAR VE AKIŞKANIN POMPADAN SIZMASINI SAĞLAR. ÇÖZÜM OLARAK POMPANIN GİRİŞİNE SEVİYE SENSÖRÜ TAKILMALIDIR.

PLASTIC ACID PUMPS ARE REALLY SIMPLE PUMPS AS WORKING PRINCIPLE. DRY WORK IS ONE OF THE BIGGEST PROBLEMS EXPERIENCED IN PUMPS. WHEN THE PUMP STAYS DRY WHILE TRANSFERING FLUID, THE PACKAGING OVERHEATS AND CORNS, ALLOWING FLUID TO LEAK FROM THE PUMP. AS A SOLUTION, A LEVEL SENSOR MUST BE INSTALLED INTO THE PUMP'S INPUT.

DİĞER BİR SORUN PARTİKÜLLÜ AKIŞKAN TRANSFERLERİNDE YAŞANMAKTADIR. AKIŞKAN İÇERİSİNDEKİ PARTİKÜLLER FANA VE SALMASTRAYA ZARAR VERİR . BU DURUMDA POMPANIN GİRİŞİNİN ÖNÜNE FİLTRE TAKILMALIDIR.

ANOTHER PROBLEM IS EXPERIENCED IN PARTICULATE FLUID TRANSFERS. PARTICLES IN THE FLUID DAMAGE FAN AND SEALING. IN THIS CASE, A FILTER MUST BE INSTALLED IN FRONT OF THE PUMP'S INLET.

POMPANIN ÇIKIŞ BASINCINA DİKKAT EDİLMEYEN YAPILAN AKIŞKAN TRANSFERLERİNDE MOTOR VE SALMASTRA ZARAR GÖREBİLİR. BU DURUMU ÖNLEMELİK İÇİN TRANSFER İŞLEMİNDEN ÖNCE POMPANIN TEKNİK DEĞERLERİNE BAKMAK GEREKİR.

ENGINE AND SEAL MAY BE DAMAGED IN FLUID TRANSFERS MADE WITHOUT ATTENTION TO THE PUMP'S OUTPUT PRESSURE. TO AVOID THIS SITUATION, IT IS NEEDED TO CONSIDER THE TECHNICAL VALUES OF THE PUMP BEFORE THE TRANSFER PROCESS.

dia pump[®]